

FLUID COOLING | P-Bar Series Mobile MA

AIR COOLED MA

BRAZED ALUMINUM CONSTRUCTION

Features

- Bar and Plate Brazed Aluminum Core
- Rugged, lightweight, and compact
- Provides the best heat transfer per given envelope size while minimizing pressure drop
- Air-side fin design minimizes fouling and static pressure ensuring long-term, reliable performance
- Fan motor assembly has an IP68 with AMP-#180908 connection
- Welded aluminum fittings/ports and manifolds ensure structural integrity
- Standard SAE ports – NPT and BSPP ports available
- Customized units are available to meet your specific performance requirements
- Additional capabilities for radiators, charge-air-coolers, condensers, and multi-circuit units
- Optional temperature sensors (see pg. 171)



30/60 psi Bypass available

Ratings

Maximum Operating Pressure

250 psi (17 BAR)

Maximum Operating Temperature

300° F (150° C)

Fluid Compatability

Petroleum/mineral oils

Oil/water emulsion

Water/ethylene glycol

Materials

Core Brazed Aluminum Bar and Plate

- Tanks – 5052 Aluminum
- Nose Bar & Little Bar – 3003-H Aluminum
- Air Fin, Plate, Turbulator & End Plate – 3003-O Aluminum

Connections Aluminum

Core Mounting Brackets Brazed Aluminum

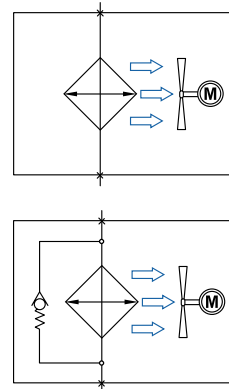

Without Bypass

With Bypass

How to Order

Model Series	Model Size Selected	Connection Type*	Bypass*	Specify Motor Required
MA (MAR)	3 3.5 4 12 18 32 48 232 248	1 - NPT 2 - SAE 3 - BSPP	30 - 30 PSI 60 - 60 PSI	4A - 12 VDC 4B - 24 VDC

*Bypass available on MA-12, MA-18, MA-32, MA-48, MA-232, MA-248 only. (MAR)

MA-8, MA-14, MA-20, MA-66, MA-32 do not have fan option.

MA 3.5 available with fan only.

Dimensions - Fan/Core

MA-3

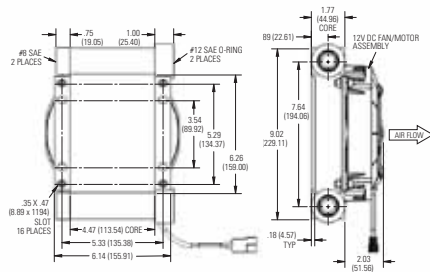

MA-3.5

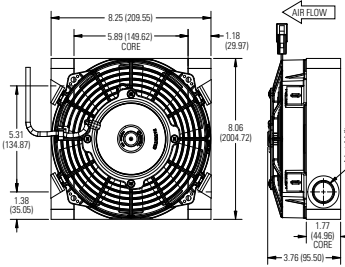

MA-4

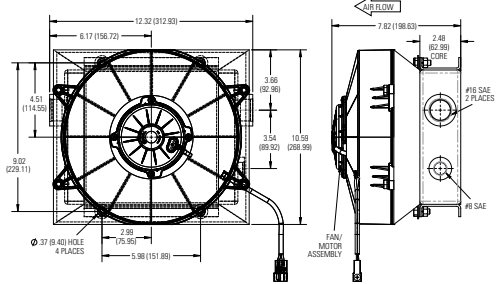

MA-12, MA-18, MA-32

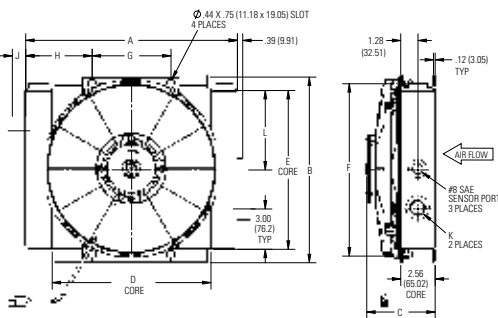

MA-232

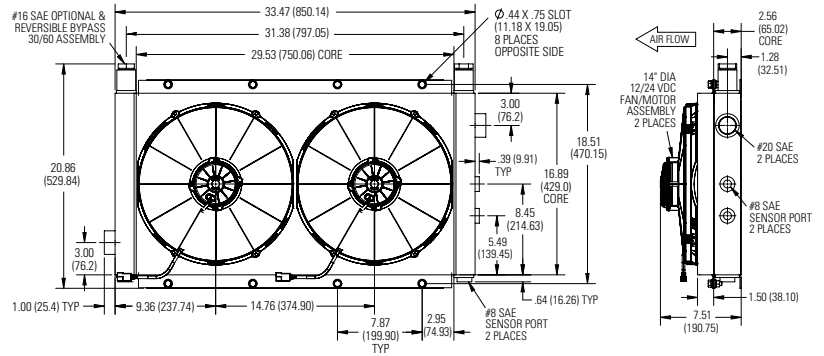

MA-48

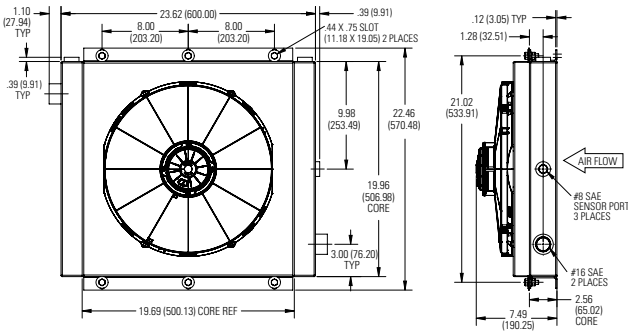

MA-248

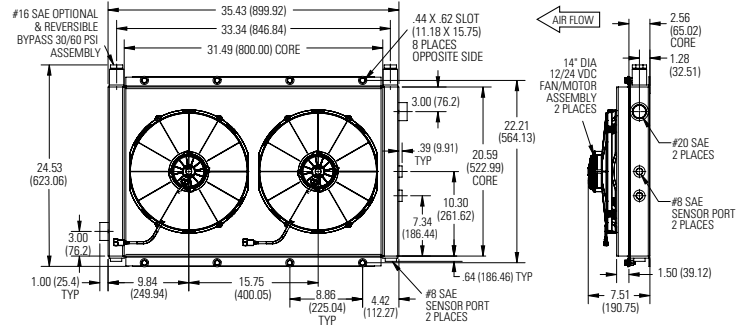

Model	A	B	C	D	E	F	G	H	J	K	L	DC Amp Draw 12V	DC Amp Draw 24V	CFM (CMM)	Approx. Ship Wt. lbs (Kg)
MA-3	See diagram above			—	—	—	—	—	—	—	—	5.7	3.6	300 (8.50)	6 (2.72)
MA-3.5	See diagram above			—	—	—	—	—	—	—	—	12.5	6.3	370 (10.48)	9 (4.08)
MA-4	See diagram above			—	—	—	—	—	—	—	—	12.5	6.3	363 (10.28)	16 (7.26)
MA-12	13.78 (350.01)	11.81 (299.97)	6.26 (159.00)	9.84 (249.94)	9.96 (252.98)	10.87 (276.10)	5.71 (145.00)	4.41 (112.01)	1.00 (25.40)	#12 SAE	4.98 (126.49)	12.5	6.3	521 (14.75)	19 (8.62)
MA-18	15.75 (400.05)	13.81 (350.77)	5.04 (128.02)	11.81 (299.97)	11.81 (299.97)	12.80 (325.12)	5.87 (149.10)	4.96 (125.98)	1.00 (25.40)	#12 SAE	5.91 (150.11)	10.6	5.3	783 (22.17)	23 (10.43)
MA-32	19.69 (500.15)	18.54 (470.92)	5.95 (151.13)	15.75 (400.05)	16.14 (409.96)	17.32 (439.93)	12.00 (304.8)	3.86 (98.04)	1.14 (28.96)	#16 SAE	8.07 (204.98)	22.2	11.1	1368 (38.74)	28 (12.70)
MA-48	See diagram above			—	—	—	—	—	—	—	—	22.2	11.1	1637 (46.40)	45 (20.40)
MA-232	See diagram above			—	—	—	—	—	—	—	—	19.3*	9.7*	2234 (63.26)	65 (29.48)
MA-248	See diagram above			—	—	—	—	—	—	—	—	19.3*	9.7*	2904 (82.24)	90 (40.80)

Note: We reserve the right to make reasonable design changes without notice. Dimensions are in inches and (millimeters).

*AMP draw listed as per FAN.

Dimensions - Core Only

AIR COOLED MA

MA-3

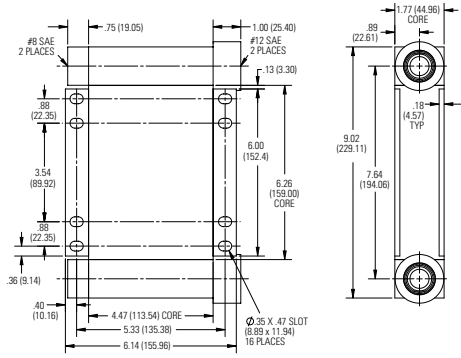

MA-4

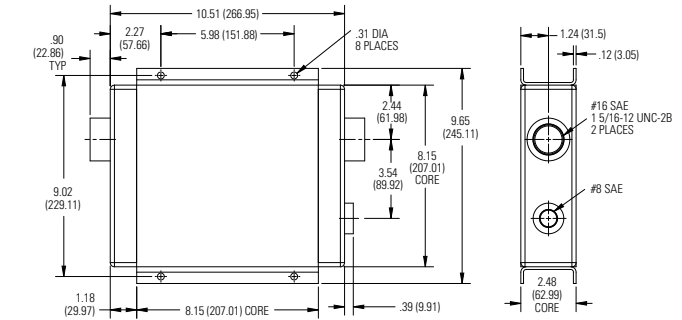

MA-8, MA-14, MA-20

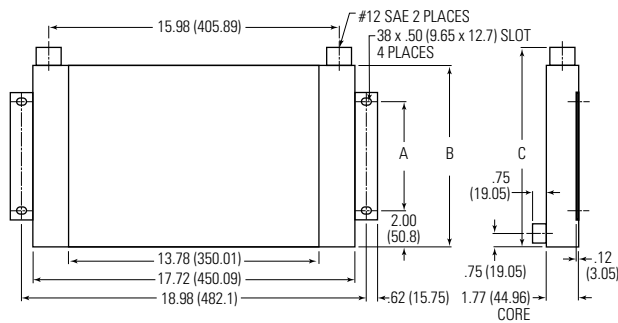

MA-12 thru MA-120

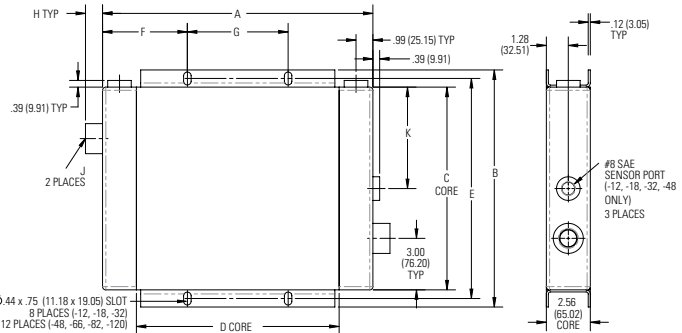

MA-232

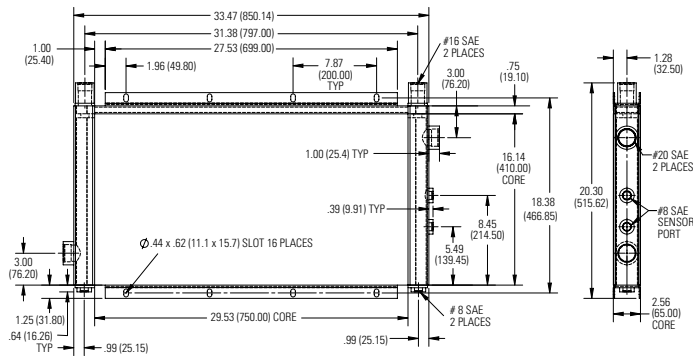

MA-248

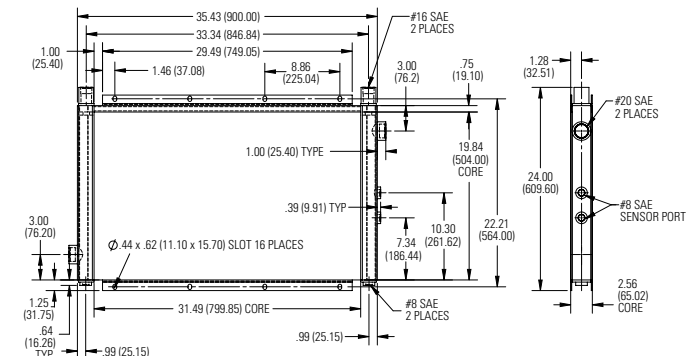

Model	A	B	C	D	E	F	G	H	J	K	Approx. Ship Wt. lbs (Kg)
MA-3	See diagram above										4 (1.81)
MA-4	See diagram above										7 (3.18)
MA-8	3.00 (76.2)	5.67 (144.02)	6.65 (168.9)								10 (4.54)
MA-12	13.78 (350.01)	11.81 (299.97)	9.96 (252.98)	9.84 (294.94)	10.98 (278.89)	4.04 (102.62)	5.71 (145.03)	1.00 (25.4)	#12 SAE	4.98 (126.49)	15 (6.8)
MA-14	6.00 (152.4)	10.00 (254.0)	10.98 (278.89)								14 (6.35)
MA-18	15.75 (400.05)	13.81 (350.77)	11.81 (299.97)	11.81 (299.97)	12.82 (325.63)	4.94 (125.48)	5.87 (149.10)	1.00 (25.4)	#12 SAE	5.91 (150.11)	18 (8.16)
MA-20	10.00 (254.0)	14.33 (363.98)	15.31 (388.87)								18 (8.16)
MA-32	19.69 (500.13)	18.54 (470.92)	16.14 (409.96)	15.75 (400.05)	17.32 (439.93)	3.85 (97.79)	12.00 (304.8)	1.10 (27.94)	#16 SAE	8.07 (204.98)	28 (12.7)
MA-48	23.62 (599.95)	22.13 (562.10)	19.96 (506.98)	19.69 (500.13)	21.02 (533.91)	3.81 (96.77)	8.00 (203.2)	1.10 (27.94)	#16 SAE	9.98 (253.49)	41 (18.60)
MA-66	27.56 (700.02)	25.83 (656.08)	23.54 (597.92)	23.62 (599.95)	24.72 (627.89)	3.78 (96.01)	10.00 (254.0)	1.58 (40.13)	#20 SAE		50 (22.68)
MA-82	31.50 (800.1)	27.68 (703.07)	25.39 (644.91)	27.56 (700.02)	26.57 (674.88)	5.75 (146.05)	10.00 (254.0)	1.58 (40.13)	#24 SAE		65 (29.48)
MA-120	31.50 (800.1)	39.49 (1003.05)	37.20 (944.88)	27.56 (700.02)	38.39 (975.11)	5.75 (146.05)	10.00 (254.0)	1.58 (40.13)	#24 SAE		88 (39.92)
MA-232	See diagram above										55 (24.95)
MA-248	See diagram above										80 (36.29)

Note: We reserve the right to make reasonable design changes without notice. All dimensions are in inches and (millimeters).

Performance Curves

MA Models with DC Fan Assemblies

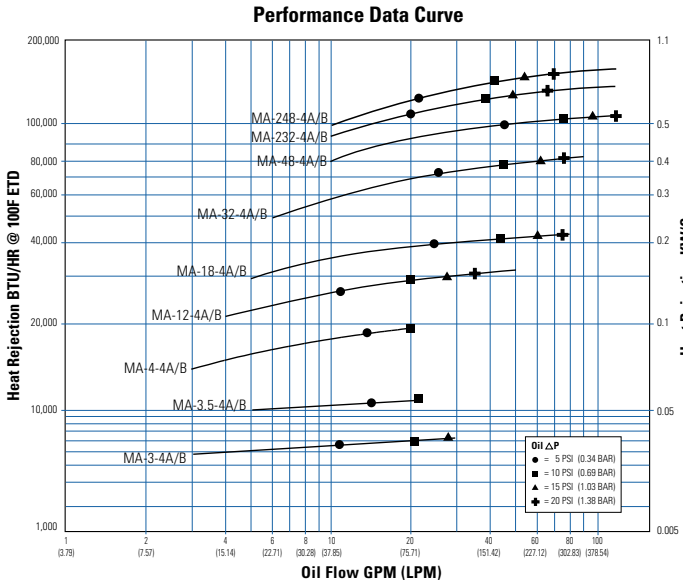

MA Models (No Fan, Core Only)

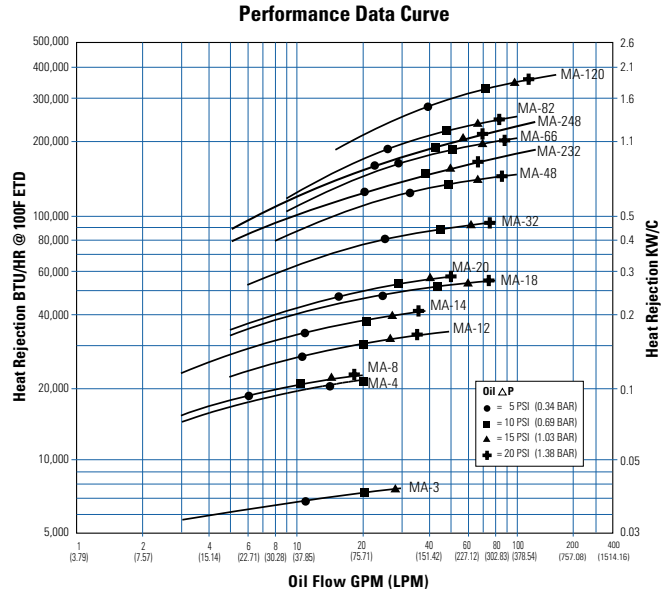

Oil Pressure Drop Correction

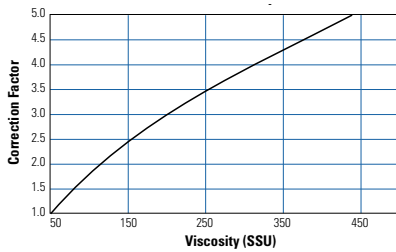

Air Static Correction

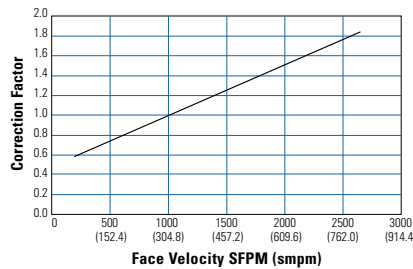

Air Static Pressure Drop

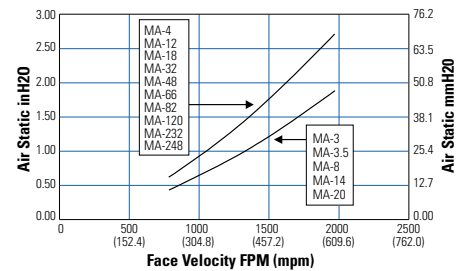

Selection Procedure

Step 1 Determine Heat Load. Typical Rule of Thumb, - size cooler for 1/3 of the input horsepower. Heat load may be expressed as either Horsepower or BTU/HR or KW/°C.

$$HP = \text{BTU/HR} \div 2545$$

$$\text{BTU/HR} = \frac{KW}{^{\circ}C} \times 1895 \times \text{E.T.D.}(^{\circ}F)$$

$$\text{BTU/HR} = HP \times 2545$$

Step 2 Determine Entering Temperature Difference. (Actual E.T.D.) (E.T.D. = Entering oil temperature – Entering Ambient air temperature)

The entering oil temperature is generally the maximum desired system oil temperature.

Entering air temperature is the highest Ambient Air temperature the application will see, plus – add any pre-heating of the air prior to its entering the cooler. Pay special attention if air is drawn from the engine compartment for cooling.

Step 3 Find Air Velocity Correction Factor (Skip to Step 4 if using our DC Fan Assembly)

Calculate actual SFPM Air Velocity or SCFM (Standard Cubic Feet per Minute) for selection using the Face Area from the table.

$$\text{SFPM Air Velocity}^* = \frac{\text{SCFM Air Flow}}{\text{Square Feet Cooler Face Area}}$$

$$\text{SMPM} = \frac{\text{SCMM}}{\text{Square Meter Cooler Face Area}}$$

(SCFM Air Flow = SFPM Air Velocity x Square Feet Cooler Face Area)

*If the Air Velocity calculated is different than the value in Step 4, then recheck Corrected oil Pressure drop.

Step 4 Determine the Corrected Heat Dissipation to use the Curves
ENGLISH Version

$$\text{Corrected Heat Rejection} = \frac{\text{BTU/HR}}{\text{Heat Load}} \times \left[\frac{100^{\circ}F}{\text{Desired E.T.D.}} \times \frac{\text{Air Velocity}}{\text{Correction Factor}} \right]$$

(BTU/HR) to use with selection chart

(Air Factor value not needed if using provided DC Fan assembly; Omit in formula)

METRIC Version

$$\text{Corrected Heat Rejection} \left[\frac{KW}{^{\circ}C} \right] = \frac{\text{Heatload (kw)}}{\text{Desired E.T.D.}(^{\circ}C) \times \text{Correction Factor} \times \text{Air Velocity}}$$

Step 5 Select Model From Curves Enter the Performance Curves at the bottom with the GPM oil flow and proceed upward to the adjusted Heat Rejection from Step 4. Any Model or Curve on or above this point will meet these conditions.

Step 6 Calculate Oil Pressure Drop Find the oil pressure drop correction factor and multiply it by the Oil Pressure Drop found on performance curve.

Listed Performance Curves are based on:

- 50 SSU (11 cSt) oil
 - 1000 Standard Feet per Minute (SFPM) (304.8 MPM) Air Velocity
 - 100° F (55.56° C) Entering Temperature Difference (E.T.D.)
- If your application conditions are different, then continue with the selection procedure.